

NORTH EASTERN RAILWAY

VARANASI DIVISION

PRODUCED BY AN AUTODESK EDUCATIONAL PRODUCT

PRODUCED BY AN AUTODESK EDUCATIONAL PRODUCT

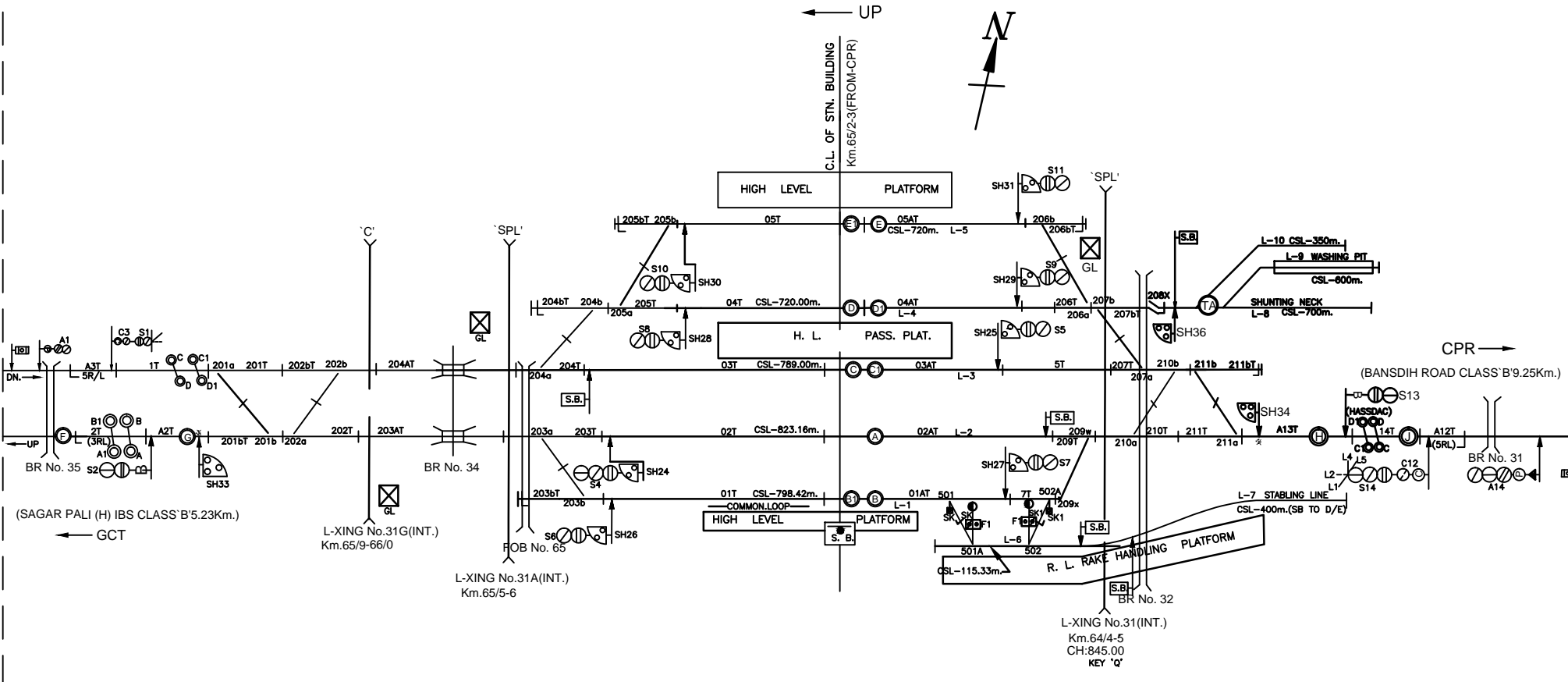

NOTE-

- 1. GAUGE - B.G.
- 2. CLASS - B
- 3. STANDARD OF INTERLOCKING - III
- 4. BLOCK WORKING -
  - i. BPAC USING BLOCK PANEL WITH UFSBI ON SINGLE LINE SECTION BALLIA - BANSDIH ROAD
  - ii. LOCK & BLOCK INSTT. WITH IBS ON DOUBLE LINE SECTION BALLIA - PHEPHNA

NOT TO SCALE    BASED ON R.D. No. Dy.CSTE /CON./ BSB / 2020(RD) /12    ALT-'NILL'

MINIATURE PLAN

**BALLIA**

(BUI)