

NORTH EASTERN RAILWAY

VARANASI DIVISION

PRODUCED BY AN AUTODESK EDUCATIONAL PRODUCT

PRODUCED BY AN AUTODESK EDUCATIONAL PRODUCT

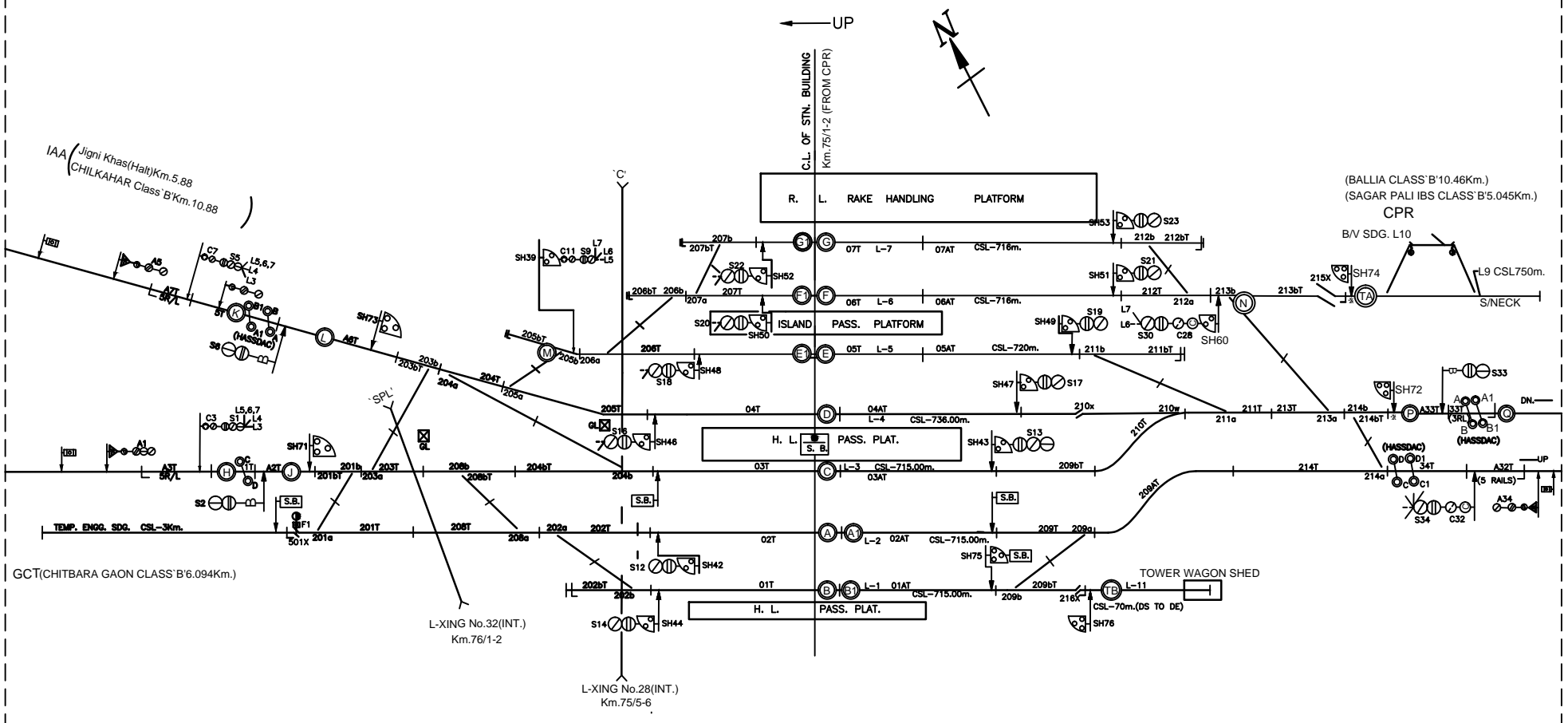

NOTE-

1. GAUGE - B.G.
2. CLASS - B
3. STANDARD OF INTERLOCKING - II (E)
4. BLOCK WORKING -
 - i. LOCK & BLOCK INSTT. AND IBS WITH A/C DOUBLE LINE SECTION PHEPHANA - SAGARPALI
 - ii BPAC WITH UFSBI ON SINGLE LINE SECTION PHEPHANA - CHITBADAGAON
 - iii BPAC WITH UFSBI ON SINGLE LINE SECTION PHEPHANA - CHILKAHAR.

NOT TO SCALE BASED ON R.D.No. DY.CSTE/CON./BSB/2020(RD)/13 ALT.- NILL

MINIATURE PLAN

PHEPHANA Jn.

(PEP)